

S = STRAIGHT

\*\*FOR A-THREAD DIMENSIONS AND MAX ENTRY SIZE REFER PAGE-H

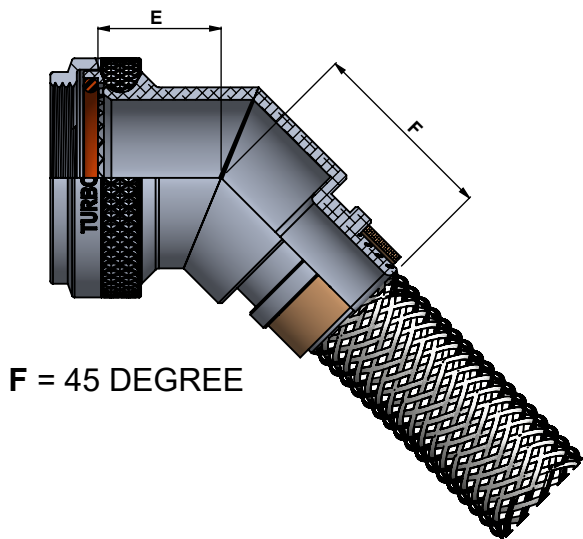

F = 45 DEGREE

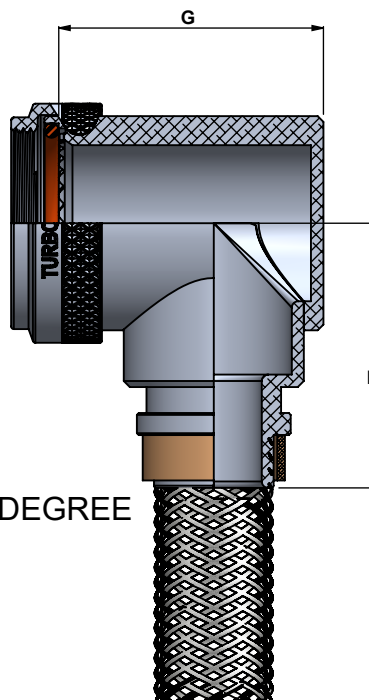

N = 90 DEGREE

**ORDERING INFORMATION**

**TBS 51 - H 3 F VB - 17 08 - 8 - 6**

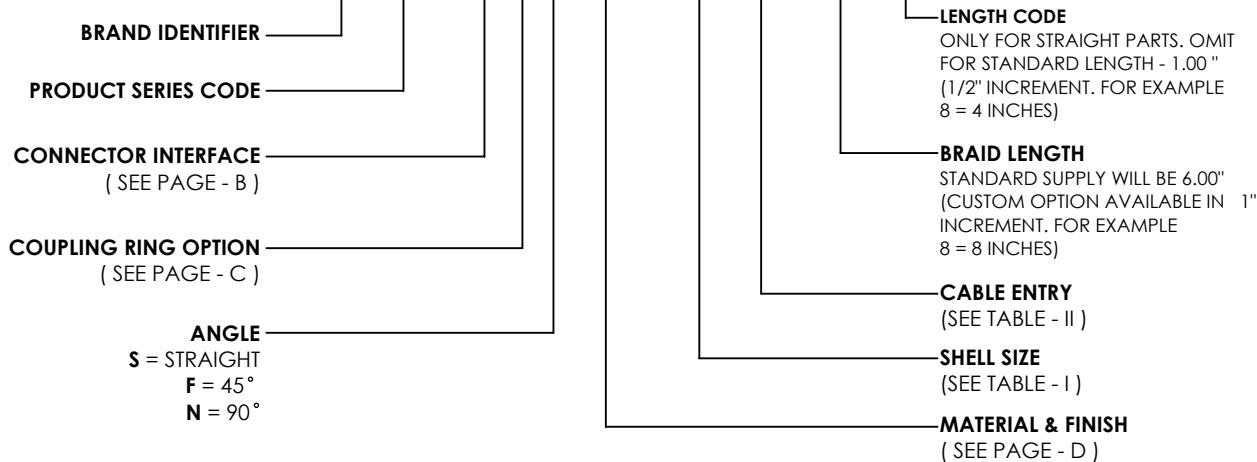

REVISIONS				DRAWN :	AD	DATE
REV NO.	REVISED BY	DATE OF REV	APPROVED BY	CHECKED :	AD	30-01-2020
01	VN	06-01-2021	AD	APPROVED :	MR	30-01-2020

**TURBO INDIA**  
INTERCONNECT SOLUTIONS  
#114, 1st Floor, P C Industrial Estate, Kamakshipalya,  
Magadi Rd, Bangalore 560 079, Karnataka, India

THIS DRAWING IS COPYRIGHT AND THE PROPERTY OF TURBO INDIA INTERCONNECT SOLUTIONS. IT MUST NOT BE COPIED, USED FOR MANUFACTURE OR OTHERWISE DISCLOSED WITHOUT PRIOR WRITTEN CONSENT OF THE COMPANY.

UNLESS OTHERWISE SPECIFIED : ALL DIMENSIONS IN MILLIMETRES  
GENERAL TOL: LINEAR : ± 0.10MM  
ANGULAR : ± 2°

MATERIAL :	---	<b>REV.No</b> <b>01</b>
WEIGHT :	---	
<b>ASSEMBLY USED ON:</b>		
---		

**DESCRIPTION :**  
**EMI/RFI SHIELD SOCK - SHRINK BOOT ADAPTER**

**PART NUMBER / SERIES:**  
**SERIES 51**

TABLE - I SHELL SIZE							
CONNECTOR DESIGNATOR			RING DIMENSION	ELBOW DIMENSIONS			
A	F & D	H	Ø C MAX	E MAX	F MAX	G MAX	H MAX
08	08	09	22.48	21.90	26.50	25.70	29.30
10	10	11	25.65	22.70	27.30	26.70	31.10
12	12	13	28.83	23.20	27.90	31.20	32.60
14	14	15	32.00	23.70	28.60	37.20	34.20
16	16	17	35.18	24.40	29.10	40.20	35.70
18	18	19	38.35	24.90	29.60	44.70	37.00
20	20	21	41.53	25.70	30.40	49.20	38.70
22	22	23	44.70	26.20	30.90	51.70	40.00
24	24	25	47.88	27.00	31.60	53.20	41.80

TABLE- II CABLE ENTRY		
DASH NO	Ø J +0.20	Ø L MAX
03	4.70	12.40
04	6.30	14.00
05	7.90	15.60
06	9.50	17.20
07	11.10	18.80
08	12.70	20.40
09	14.20	21.90
10	15.80	23.50
11	17.40	25.10
12	19.00	26.70
13	20.60	28.30
14	22.20	29.90
15	23.80	31.50
16	25.40	33.10
17	27.00	34.70
18	28.60	36.30
19	30.20	37.90
20	31.80	39.50
21	33.30	41.00
22	35.00	42.70
23	36.50	44.20
24	38.10	45.80

1. WHEN MAXIMUM CABLE ENTRY IS EXCEEDED , STYLE-2 WILL BE SUPPLIED . IN THAT CONDITION, DIMENSIONS E,F,G AND H WILL NOT APPLY.
2. FOR ANY KIND OF CUSTOMISATION/SHELL SIZE ON THIS BACKSHELL, FOR TERMINATION BANDS AND OTHER ACCESSORIES REACHOUT TO US ON [sales@turboindia.co.in](mailto:sales@turboindia.co.in)

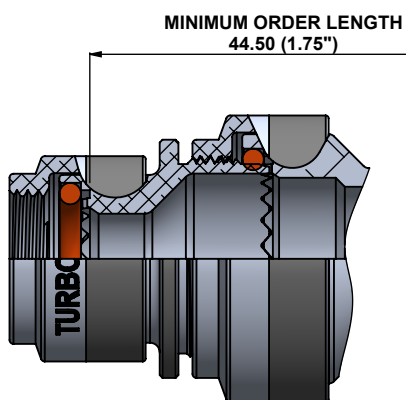
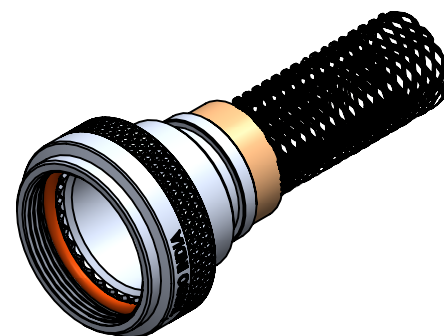

STYLE -2  
STRAIGHT

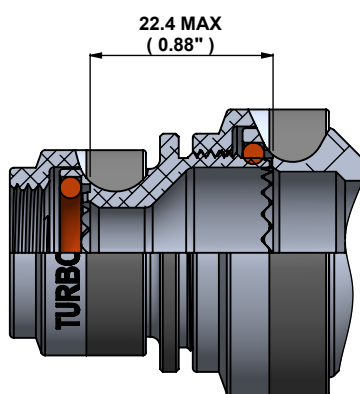

STYLE -2  
45° & 90°

THIS DRAWING IS COPYRIGHT AND THE PROPERTY OF TURBO INDIA INTERCONNECT SOLUTIONS. IT MUST NOT BE COPIED, USED FOR MANUFACTURE OR OTHERWISE DISCLOSED WITHOUT PRIOR WRITTEN CONSENT OF THE COMPANY.

UNLESS OTHERWISE SPECIFIED : ALL DIMENSIONS IN MILLIMETRES  
GENERAL TOL:  
LINEAR : ± 0.10MM  
ANGULAR : ± 2°

		DATE
DRAWN :	AD	30-01-2020
CHECKED :	AD	30-01-2020
APPROVED :	MR	30-01-2020
MATERIAL :	---	REV.No 01
WEIGHT :	---	
ASSEMBLY USED ON:		---

 <p><b>TURBO INDIA</b> INTERCONNECT SOLUTIONS #114, 1st Floor, P C Industrial Estate, Kamakshipalya, Magadi Rd, Bangalore 560 079, Karnataka, India</p>	DESCRIPTION :
	EMI/RFI SHIELD SOCK - SHRINK BOOT ADAPTER
PART NUMBER / SERIES:	
SERIES 51	

## CONNECTOR INTERFACE DATA

TICS offers interconnect solutions for almost all known connector interfaces. The variants highlighted below are the standard lines available on all our products. To discuss connector interface options not listed below, send us a message to [sales@turboindia.co.in](mailto:sales@turboindia.co.in)

TURBO INTERFACE CODE	EQUIVALENT INTERFACE DESIGNATION OF VARIOUS BRANDS				BACKSHELLS DESIGNED TO BE USED IN CONNECTOR SERIES
	POLAMCO	AMPHENOL	GLENAIR	RAYCHEM	
A	A	J	A	54	MIL-DTL-5015H
A	A	J	A	54	MIL-DTL-83723 SERIES III (BAYONET)
A	A	J	A	54	MIL-DTL 83723 SERIES III (THREADED)
F	F	K	F	41	MIL-DTL-38999 SERIES I (odd numbered shell sizes)
F	F	K	F	41	MIL-DTL-38999 SERIES II (even numbered shell sizes)
D	DG, KG, DM, K, DS, UT	-	D	21	MIL-DTL-26482 SERIES I SOLDER
H	H	L	H	40	MIL-DTL-38999 SERIES III / EN3645
H	H	L	H	40	MIL-DTL-38999 SERIES IV
B	L, LS, LM, LV	J	B	18	MIL-DTL-5015 SOLDER M3100, MS3101, MS3106, Amphenol - Class A (Blue Insert)

## COUPLING RING OPTIONS



### Direct Coupling (1)

The coupling nut is eliminated in this design, and the backshell directly threads to the connector.

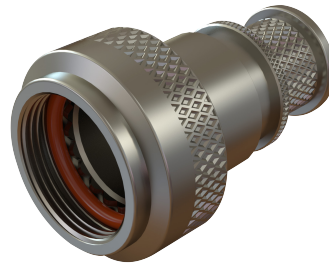

### Free Spinning (3)

Free Spinning Adapters makes the assembly of the backshell to the connector easy without turning the entire backshell body. The coupling nut is free to rotate in this design.

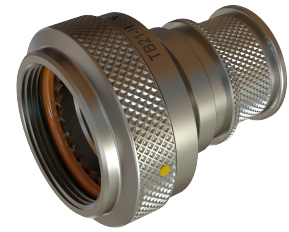

### Self Lock - Detent (5)

The movement of coupling nut is locked by means of an anti-decoupling device in this design. The Self Lock adapters are the most popular among the many backshell adapter variants.



### Self Lock - Non Detent (7)

In this design, the coupling nuts are locked in a pre-tensioned condition to achieve the Self Lock feature.



### Wrench Flat (9)

Wrench flats option is available in our backshell, allowing for an easier way of tightening the coupling ring using a wrench or spanner, when working with reduced accessibility.

## MATERIAL & FINISH CODE

TURBO CODE	MILITARY CODE	MATERIAL	PLATING	PROCESS	ROHS COMPLIANT
A	A	ALUMINIUM	<b>ANODIZING BLACK</b>	AMS-A-8625 Type II Class 2, 336 Hour Salt Spray, Non-Conductive -65 to +175°C	YES
AH	-	ALUMINIUM	<b>ANODIZE - HARDCOAT BLACK</b>	AMS-A-8625 Type III, Class 2, .001 thick, 336 Hour Salt Spray, Non-Conductive -65 to +200°C	YES
N	N	ALUMINIUM	<b>ELECTROLESS NICKEL</b>	AMS-C-26074 Class 4 Grade B; ASTM-B-733, SC 2, Type IV, 96 Hour Salt Spray, Conductive -65 to +200°C	YES
W	W	ALUMINIUM	<b>CADMIUM - OLIVE DRAB</b>	SAE-AMS-QQ-P-416 Type II Class 2 over Electroless Nickel 500 Hour Salt Spray, Conductive -65 to +175°C	NO
WS	W	ALUMINIUM	<b>CADMIUM - OLIVE DRAB</b>	SAE-AMS-QQ-P-416 Type II Class 2 over Electroless Nickel 1000 Hour Salt Spray, Conductive -65 to +175°C"	NO
Z	Z	ALUMINIUM	<b>ZINC NICKEL - BLACK</b>	ASTM B841 Grade 5 over Electroless Nickel 500 Hour Salt Spray, Conductive -65 to +175°C	YES
VB	-	ALUMINIUM	<b>ZINC COBALT - BLACK</b>	ASTM B 840 Grade 6 Type D over Electroless Nickel 350 Hour Salt Spray, Conductive -65 to +175°C	YES
VO	-	ALUMINIUM	<b>ZINC COBALT - OLIVE DRAB</b>	ASTM B 840 Grade 6 Type D over Electroless Nickel, 350 Hour Salt Spray, Conductive -65 to +175°C	YES
NU	-	MARINE BRONZE	<b>UNPLATED</b>	1000 Hour Salt Spray, Conductive -65 to +200°C	YES
NS	-	MARINE BRONZE	<b>SHOT BLASTED</b>	1000 Hour Salt Spray, Conductive -65 to +200°C	YES
S	S	STAINLESS STEEL	<b>PASSIVATION</b>	SAE-AMS-SAE-AMS-QQ-P-35 Type VI 1000 Hour Salt Spray, Conductive -65 to +200°C	YES
BC	B	STAINLESS STEEL	<b>CADMIUM BLACK</b>	SAE-AMS-QQ-P-416 Type II Class 3 48 Hour Salt Spray, Conductive -65 to +175°C	NO

The above list is not exhaustive, additional finishes related to specific applications can be provided. Send us an email to [sales@turboindia.co.in](mailto:sales@turboindia.co.in).

## INTERFACE TABLE

A-INTERFACE		
SHELL SIZE	A- THREAD	MAX ENTRY
08	1/2 - 20 UNEF	04
10	5/8 - 24 UNEF	06
12	3/4 - 20 UNEF	08
14	7/8 - 20 UNEF	09
16	1 - 20 UNEF	11
18	1-1/16 - 18 UNEF	12
20	1-3/16 - 18 UNEF	14
22	1-5/16 - 18 UNEF	16
24	1-7/16 - 18 UNEF	18

H-INTERFACE		
SHELL SIZE	A- THREAD	MAX ENTRY
09	M12 x 1.0	05
11	M15 x 1.0	07
13	M18 x 1.0	09
15	M22 x 1.0	11
17	M25 x 1.0	13
19	M28 x 1.0	14
21	M31 x 1.0	16
23	M34 x 1.0	18
25	M37 x 1.0	20

D-INTERFACE		
SHELL SIZE	A- THREAD	MAX ENTRY
08	7/16 - 28 UNEF	04
10	9/16 - 24 UNEF	06
12	11/16 - 24 UNEF	08
14	13/16 - 20 UNEF	10
16	15/16 - 20 UNEF	12
18	1-1/16 - 18 UNEF	14
20	1-3/16 - 18 UNEF	16
22	1-5/16 - 18 UNEF	18
24	1-7/16 - 18 UNEF	20

F-INTERFACE		
SHELL SIZE	A- THREAD	MAX ENTRY
08	7/16 - 28 UNEF	04
10	9/16 - 24 UNEF	06
12	11/16 - 24 UNEF	08
14	13/16 - 20 UNEF	10
16	15/16 - 20 UNEF	12
18	1-1/16 - 18 UNEF	14
20	1-3/16 - 18 UNEF	16
22	1-5/16 - 18 UNEF	18
24	1-7/16 - 18 UNEF	20

## POPULAR CROSS REFERENCE WITH TURBO PRODUCT SERIES

CIRCULAR BACKSHELLS								
TURBO SERIES CODE	GLENAIR				TE / POLAMCO			
	INTERFACE CODE				INTERFACE CODE			
	A	H	F	D	A	H	F	D
SERIES 21	440AS030	440HS030	440FS030	440DS030	91A	91H	91F	91D
SERIES 31	440AS084	440HS084	440FS084	440DS084	60A	60H	60F	60D
SERIES 41	310AS001	310HS001	310FS001	310DS001	97A	97H	97F	97D
SERIES 51	319AS001	319HS001	319FS001	319DS001	70A	70H	70F	70D
SERIES 54	620AS046	620HS011	620FS012	-	96A	96H	96F	96D
SERIES 61	311AS001	311HS001	311FS001	311DS001	95A	95H	95F	95D
SERIES 64	450AS001	450HS001	450FS001	450DS001	86A	86H	86F	86D
SERIES 110-01	370AS001	370HS001	370FS001	370DS001	37A	37H	37F	37D
SERIES 110-02	360AS001	360HS001	360FS001	360DS001	37A(NE)	37H(NE)	37F(NE)	37D(NE)
SERIES 110-03	390AS011	390HS011	390FS011	390DS011	39A	39H	39F	39D
SERIES 110-04	380AS005	380HS005	380FS005	380DS005	39A(NE)	39H(NE)	39F(NE)	39D(NE)
SERIES 120-01	440AC030	440HC030	440FC030	440DC030	BTA3C	BTH3C	BTF3C	BTD3C
SERIES 160-01	443AS009	443HS009	443FS009	443DS009	88A	88H	88F	88D
SERIES 160-02	447AS425	447HS425	447FS425	447DS425	88A(NE)	88H(NE)	88F(NE)	88D(NE)

PROTECTIVE COVERS		
TURBO SERIES CODE	GLENAIR	TE / POLAMCO
SERIES 12	660-012	PPC27501
SERIES 13	660-013	PRC27502
SERIES 22	660-014	PPC27510
SERIES 23	660-015	PRC27511
SERIES 32	660-023	100P237
SERIES 33	660-024	100P160
SERIES 42	660-031	100P609
SERIES 43	660-032	100P608
SERIES 52	660-008	PPC3180
SERIES 53	660-009	PRC3181
SERIES 62	660-004	100P1167
SERIES 63	660-005	100P1240

RECTANGULAR BACKSHELL		
TURBO SERIES CODE	GLENAIR	TE / POLAMCO
TBARC-P-X	527-108	ARC600-3
TBDSBND-01	557T246	D25-1-BT
TBDSBND-02	557B319	D25-2A-91
TBDSBND-03	557-200	D25-3A-91

DUMMY RECEPTACLE		
TURBO SERIES CODE	GLENAIR	TE / POLAMCO
TBDSR-01	VG95234B0D	PC95234DR
TBDSR-02	650-074	100P3062-R
TBDSR-03	D38999/22	100P939